

XTAL

DECEMBER

1948

Vol. X No. 12

for the
**radio
amateur**

J. Davidson, VE3BGN,
R. R. 3,
Acton, Ont. 1/49.

A Merry Christmas

and

**A Happy
New Year**

for All



is the wish of CAROA



THE CANADIAN A

...L JOURNAL
... RADIO OPERATORS' ASSOCIATION
... O, ONTARIO



HAMMOND

The Name to Remember!

CANADIAN AMATEURS HAVE BEEN USING HIGH QUALITY HAMMOND PRODUCTS FOR OVER TWENTY YEARS. WE ARE PROUD OF THIS BACKGROUND OF SERVICE AND EXPERIENCE. CONSTANT RESEARCH AND DEVELOPMENT TOGETHER WITH A HIGH PRODUCTION STANDARD MERITS YOUR CONTINUED CONFIDENCE IN CANADA'S ONLY COMPLETE TRANSFORMER LINE.

- Plate Transformers
- Filament Transformers
- Power Transformers
- Modulation Transformers
- Audio Transformers
- Vibrator Transformers
- H.V. Rect. Fil. Transformers
- 6 Meter Rotary Beams
- 10 Meter Rotary Beams
- 20 meter Rotary Beams
- Swinging Chokes
- Smoothing Chokes
- R.F. Chokes
- Metal Chassis
- Metal Panels
- Metal Cabinets
- Metal Racks
- Transmitting Condensers
- Neutralizing Condensers
- Beam Position Indicators

Distributed Through Leading Jobbers From Coast to Coast

HAMMOND MANUFACTURING COMPANY

Limited
CO.
GUELPH · ONTARIO · CANADA

UNCIL E

★ Surplus Specials from the Stampede City JAS. SMALLEY Jr.—JOBBER

523 - 8TH AVE. WEST, CALGARY, ALBERTA

VE6GD	VE6TM	VE6AO	VE6SN	VE6HQ	VE6KJ	VE6NE
TRANSMITTERS:						
AT-1 12 volt CW/PHONE.....		\$29.50*		RMC-101 Trans Section.....		\$ 7.50
AT-7 24 volt CW/PHONE.....		29.50*		1154		10.00
TA12B 24 volt CW.....		37.50*		Command Transmitter, 2.1 to		
MODULATOR for TA12B.....		15.00		3 mcs., less tubes.....		5.00
TRANSMITTER RECEIVERS:						
ATR-5 12 volt.....		35.00*		1196		5.00
ATR-8 24 volt.....		35.00*		ADC Less power unit.....		15.00
RECEIVERS:						
MN-26 Radio Compass.....		25.00*		AR-15 RF Units, 200-400 KC..		5.00
AR-2 (Limited Quantity).....		37.50*		AR-15 IF/Power Units.....		5.00
RH Units. IFF. Less Power Transformer and Choke.....						25.00
RADAR TRANSMITTERS:						
TR-3191		1.00		ASD MD4PS-2		15.00
Air Force TC3040.....		10.00				
RADAR RECEIVERS:						
R-3039		5.00		R-3515		5.00
R-1125A50		R-1124A and C.....		3.50
RADAR AND VHF TRANSMITTER RECEIVERS:						
BC-800A		15.00		ABK-5		15.00
APN-1 Absolute Altimeters less dynamotor.....						9.75
HOMING ADAPTERS:						
238-258 mcs. Can be converted to 10 meter convertor. Uses						
4/954 tubes. New with all spares.....						12.50
RADAR RECEIVER INDICATOR UNITS:						
English 182A 5 inch tube.....		3.95		ASG Repeater Ind. CPR55ACG		1.00
ASV Indicators. Make good ham scope when converted.....						15.00
184A 5 and 2 inch tubes.....		8.95		ASD Ind. CS55ACE.....		1.00
LORAN INDICATORS:						
Can be made into Servicemans Scope. Model APN-4 *						30.00
RECEIVER AND INDICATOR COMBINATION:						
R-49-APS-25 Approx 40 standard tubes, 3 meters.....						49.50
RADAR MODULATORS AND POWER UNITS:						
Type 64 English Modulator.....						1.00
Type 280 English Power Unit.....						1.00
UHF WAVEMETER:						
Type W1158. Uses 3 inch O-1MA, etc.....						7.50
Oscillator type 12A.....						15.00
INTERPHONE PRE AMPS:						
RCAF 10D4240. Uses pair of 6SJ7 Carbon or magnetic mike.....						3.50
Packard Bell US Signal Corps. Uses 6SL7GT and 28D7.....						1.00
Signal Corps BC709A Battery Operated using 3S4.....						5.00
MISCELLANEOUS UNITS:						
Type 27 RF Units.....						2.50
Type 207 Tuning Units.....						1.00
Push Button Heads SCR522.....						1.50
Used 829B						5.00
1 mfd 25000 DCW Oil.....						7.50
Used 715A						1.00
ASD Indicator Amplifiers. Tube Lineup: 5U4G, 2X2A, 13-4, 2/6L6G, VR105,						
4/6AG7, 7/6SN7GT, 6AC7						15.00

"Schematic diagrams available with the purchase of sets marked with asterisk."

PLUS: The largest ham store in the West. Thousands of Radio, Radar and Aircraft Spares.

NOTE: Transmitters sold only to licensed operators.

FAST DELIVERY
ANYWHERE IN CANADA



STOCKS OF
**TRANSMITTING
 INDUSTRIAL
 RECEIVING TYPE
 TUBES**

Maintained in every
 Marketing Area
 for
**BETTER DELIVERY
 BETTER SALES
 MORE PROFITS**

CANADIAN GENERAL ELECTRIC CO. LTD. 48-TU-8

SALES OFFICES MAINTAINED AT:—

SYDNEY	HALIFAX	ST. JOHN	QUEBEC	CHICOUTIMI	MONTRÉAL	SHERBROOKE	MONTREAL
OTTAWA	TORONTO	HAMILTON	ST. CATHARINES	WINDSOR	NORANDA	WINDSOR	NORANDA
NEW LISKEARD	SUBBURY	TIMMINS	FORT WILLIAM	WINDSOR	SASKATOON	REGINA	SASKATOON
LETHBRIDGE	EDMONTON	CALGARY	TRAIL	VANCOUVER	VICTORIA	VANCOUVER	VICTORIA

TURNER
CON
 NCIL E



XTAL

[CRYSTAL]

VOL. X
No. 11



NOVEMBER
1948

Published by
THE CANADIAN AMATEUR RADIO OPERATORS' ASSOCIATION

46 ST. GEORGE ST., TORONTO 5, ONTARIO
TEL. Midway 8235

Contents

	Page
Editorial	4
Ten Meter Converter.....	5
Traffic Handlers' Page.....	6
B.E.R.U. Results	9
DX News	10
Introducing Your D.R.....	11
So I Added NBFM.....	12
Welcome OM!	16
QSL's Waiting	18

STAFF

Editor
T. G. E. Powell, Ve3ZE

DX Editor
R. D. Carter, Ve3QD

Advertising Manager
Don Fairbrother

Authorized as second class mail, Post Office Department, Ottawa.

CAROA

Affiliated with
A.R.R.L. and R.S.G.B.

OFFICERS

President
T. G. E. Powell, Ve3ZE

Vice-President
R. A. R. Macdonald, Ve3APS

EXECUTIVE COMMITTEE

The Officers and,
W. H. Anderson, Ve3AAZ
A. A. McArthur, Ve3DJ
A. Palmer, Ve3WK
P. Posnikoff, Ve3BBN
J. Staley, Ve3GR
H. A. M. Whyte, Ve3BWY

DISTRICT REPRESENTATIVES

Phil Loosen, Ve1KQ
F. G. Gribben, Ve2XR
W. Bert Knowles, Ve3QB
Les Saul, Ve4FJ
A. C. Cox, Ve5BF
W. R. Savage, Ve6EO
Ernie Savage, Ve7FB
Jack Spall, Ve8AS

CAROA



On the EDITOR'S FREQUENCY....

SEASON'S GREETINGS

This is a special time of the year. It is the time when holly leaves and mistletoe break out; when red bells, and green ones, come forth. It is the time of the year when the symbolic gentleman of rotund proportions makes his appearance. It is the time of the year when men speak in terms of goodwill to all. It is the time when the quiet soothing music of chiming church bells brings peace to distressed minds and troubled hearts. It is the time of the year when we are profoundly impressed by a consciousness of the solemnity of the Child birth.

It is the Christmas Season.

Those of us at headquarters pause in the performance of our daily routine to give vent to a hearty and sincere "Merry Christmas."

And because you came to know former members of the Executive Committee in an official sort of way, we extend on behalf of each and every one of them a sincere wish for a joyous festive season.

And then, present and former members of the Executive Committee join in wishing our advertisers, present and former, the warmest seasons greetings.

Finally, all of us together—advertisers and members—cumulatively, join hands as we extend to every ham everywhere a deep and sincere wish for a Merry Christmas and for the very best of everything in the year 1949. It is our hope that all of you when you look at the year 1949 in retrospect will do so with a deep feeling of thanks for what the year has been.

Again, we say, "Merry Christmas and a Happy New Year."

Television Channels

Channel 1—	44- 50	megacycles
2—	54- 60	"
3—	60- 66	"
4—	66- 72	"
5—	76- 82	"
6—	82- 88	"
7—	174-180	"
8—	180-186	"
9—	186-192	"
10—	192-198	"
11—	198-204	"
12—	204-210	"
13—	210-216	"

High band television—475-890 Mc.

—3BIF.

ADVERTISERS

XTAL is ours—yours and mine. It is ours because it is the property of CAROA, and CAROA is the collective noun which represents you and me and the many hundreds of amateurs like us who have banded together to constitute an association.

You and me are proud of XTAL. It may sometimes fall short of the standard we have set for it, but we are still proud of it because it is ours. XTAL is not a commercial venture. It is of, by and for Canadian amateurs. You and me write the copy, we produce the magazine, and we read it. XTAL is very close to us because it is about you and me and our doings.

When an issue falls below the standard we do not criticize for it is not the habit of most of us to criticize ourselves or our own. Instead, we roll up our sleeves with a constructive and supporting determination to do better.

Because XTAL is yours and mine, it behooves us to take stock of our supporters. Our advertisers are our supporters—yours and mine.

When advertisers use the pages of XTAL to acquaint us of their merchandise, they are supporting you and me, and they have earned our support.

Study the next issue of XTAL, thumb through some back issues to see just who our supporters are. You will find some regulars who make your magazine a possibility. They are the people who have merchandise of interest to the Canadian amateur—more than that, they have an interest in the Canadian amateur and that interest moves them to support our institutions.

Some day we may have a story to tell about this phase of our activities—a story which is gradually unfolding itself—but in the meantime, support our advertisers.—R.M.

QVE

The annual revision of conditions of operating amateur experimental stations comes up again soon. Should our members have matters to submit for consideration, please advise the Department of Transport, CAROA headquarters now, so that the authorities will be informed of the details of our membership.

A Ten Meter Converter for the 1155

By Ray Brown, Ve 5 RB

Here is a simple converter circuit I used in my R1155 receiver to tune in the ten and eleven meter bands. I found it so satisfactory I am submitting it so that owners of 1155 and other surplus receivers may benefit from my experiments.

The unit is so small it will fit right inside your present set, has only one control (on-off), and gives you calibrated tuning on ten and eleven.

Figure 1 is the complete diagram of the converter and figure 2 shows how the two APC15 condensers and tube sockets are mounted on a piece of aluminum $3\frac{1}{2}$ " by $3\frac{1}{2}$ ". All components except the on-off switch are mounted on one side of this aluminum sheet and the tubes plug into the other or top side.

The converter is mounted below the chassis in the 1155 just behind where the Jones plugs were originally. Another aluminum panel covering this hole on which is mounted the DPST switch. Holes are drilled in the chassis of the receiver allowing the tubes to protrude above the chassis, also two small holes through which to tune the two condensers by screwdriver.

Start wiring the unit by running a ground connection from the tuning condenser, tube socket and tie point as shown Fig. 2. Next wire

heater and B+ terminal in the set. I ran the RF grid lead back through a grommited hole into the coil compartment of the receiver and soldered it to the switch point which connects to the grid of the 1st RF tube when switch is

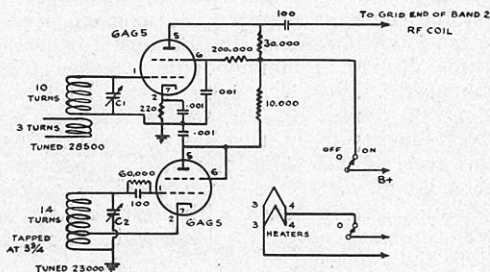
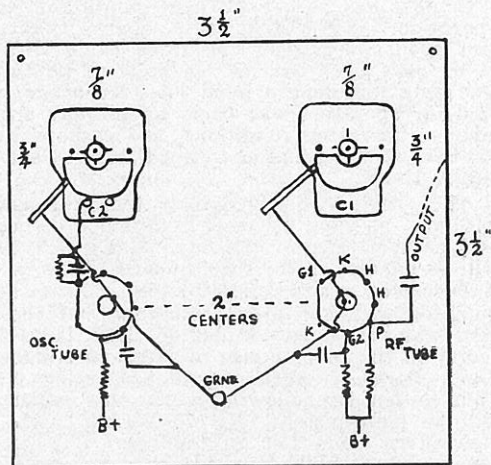

in the bypass condensers between the various socket connections and the common grounded tie point, soldering in the resistors with the same operation.

The coils are wound on opposite ends of a half-inch diameter form three inches long, and the leads solder directly onto the condensers and socket terminals with as short leads as possible. This places the coils directly over the tube sockets. The leads to the switch and heater circuits, also to the P₁ in receiver, are left long until the unit is mounted into the receiver.

When converter is fastened in place, leads can be run to the switch and to the oscillator

on band 2.—The capacity of this lead will detune the RF stage slightly on band 2, so adjust the RF trimmer on a 7Mc signal to re-align the receiver.

Now put converter on and tune the oscillator to exactly 23000 Kc with C2. The RF stage should be tuned to 28500 Kc with C1. The antenna coil of converter was connected to two small jacks with a length of 72-ohm Amphenol. Now all you have to do to tune ten meters is put converter switch on, receiver on band 2, and tune in ten meter signals between 5 and 6.7 megacycles on the receiver. Add 23,000 Kc to the dial reading on receiver and it will give you the frequency to which you are tuned.

Art Balmer, W4AI, and xyl Eleanor, from Binscarth, Man., were the guests of Dan Wood, Ve4LF, of Winnipeg, this fall. Art and Danny are old friends and have worked each other on ten meters for some time through the medium of U.S.A. contacts, including, among many, W1KWV, W6LVZ, W4LYG and W4DV. Art is a retired C.P.R. engineer and when he gets tired of operating the xyl takes over. Thanks to his U.S. contacts, he is able to keep in touch with his daughter, Thelma.—Ve4FJ.

TRAFFIC HANDLERS'

PAGE

ONTARIO 40 METER NET BULLETIN

7:30 p.m. Daily - 7267 Kc.

October has been a difficult month for Net operation. QSB, QRM, skip, hydro failures and about everything the fates could throw at us have been our lot. In spite of all this, the gang has done a good job. Much can be said for operators who carry on through such adverse operating conditions, and perhaps the experience will stand us in good stead at some future time.

ARL Texts—The Christmas traffic season will soon be upon us, when seasonal greetings will be the order of the day. Many of these will be handled in the form of ARL Texts, and it behooves every operator to become acquainted with the proper handling of these short-cut messages. A list of these texts is found on the reverse side of Message Number Sheet Form 3. Assuming that greeting No. 57 is chosen, the following is how this message will be transmitted: "NR 10 W1AW ARL 2 Newington Conn Dec 20 (address) BT Fifty seven BT (sig)." Had we chosen greeting No. 60 the check would have been ARL 1. The important thing for a receiving opr of an ARL Text to remember is that he must translate the message to read in the form of the complete greeting, which is "Wishing you the best Christmas ever," before delivery to the addressee. Never deliver a meaningless number as a text, as is sometimes done by oprs unacquainted with the proper handling of ARL Texts.

Traffic reports are made up for the calendar month and should be forwarded at end of each month to Ve3CP at Windsor for QST and this same report sent to XTAL in Toronto. These may be sent by mail or through network channels that will deliver them to their destination. The latter method is recommended as message handling is what our nets are for, and it is necessary that we use the means at our disposal to keep our tfc handling machinery in good running order.

To qualify for NET CERTIFICATE a station must QNI at least 10 times and otherwise show an interest in the net and traffic. The following stations, having met these qualifications, have been issued with the necessary document: 1, Ve3ATR; 2, Ve3IA; 3, Ve3AIL; 4, Ve3BCP.

If anyone has attempted to QNI during the past month and did not receive recognition, or has in any other way appeared to be neglected, please accept our humble apologies. We blame it largely on conditions and trust you will keep on trying.

R. LAUTENSLAGER, Ve3ATR, R.M.

QUEBEC PRACTICE NET (QPN)

The QPN (Quebec Practice Net) with Ve2GM as the net control station, is looking for new members. They hold regular Sunday morning 10.30 sessions on 3570 Kc. Their objective is (a) to provide a medium whereby a newcomer to traffic work can get some practical experience, and (b) as a result provide Ve2 with a group of fully-trained traffic and emergency operators who will form the nucleus for a province-wide Quebec net. At this writing there are GM, XB, XR and AEH taking part in the QPN and they would be pleased to have you join them. Experience is not necessary! Just your interest! Just give Ve2GM a call on 3570 Kc and he'll do the rest.

Province of Quebec Net (PQN)

An 80-meter CW net is in process of being formed to cover Quebec province. To be effective the coverage must be adequate. To get the coverage required, stations are needed in the following areas: The Eastern Townships, Three Rivers, Drummondville, Quebec City, Rimouski, Lake St. John area, Hull and Montreal proper. At this writing the time and the frequency to be used has not been decided. However, if you are interested in adding a good bit of variety to your present operating schedule, get in touch with Bert Altherr, at 268 Guilbault Ave., in Longueuil. He'll be more than pleased to hear from you.

The Alberta Net meets on 3730 Kc at 7 o'clock nightly, and needs more members.

3BCP reports for the DOT net, on 7167 daily. More stations are needed. Anyone interested write to Ve3BCP, Radio Range Station, Pagwa.

OCTOBER TRAFFIC TOTALS

2GM	35	2XB	68
2XR	21	2LO	48
3APS	49	3ATR	106
3BCP	14	3IA	65

Victoria A.E.C.

7TG is emergency co-ordinator, 7SW AEC. In charge of two-meter EC activity is 7AEB. 7AKB and 7HR are organizing things on 10. Forty and 80 meter CW activity are under 7SW and 7XA. 7SW is also AEC and OBS on 80 meter CW. 7IM is setting up a EC net on 75 phone. 7AAZ and 7CB are EC representatives to the 5 o'clock net and linking stations to mainland points. Other appointments are pending.

Disaster day will be Dec. 5 in Victoria. AEC plans are for a local net on 75 and 235 Mc at the Armories, Red Cross headquarters, police departments, VSWC clubhouse mobile stations. Links will be set up on 75, 40, 10 and 2 meters to pass traffic points. Taking part will be AEC, VSWC, Red Cross, Army units, and police departments.

QRRRR Alberni and Port Alberni

Lost all lines, slides block road and rail train missing Nov. 16-48. Twenty-four hours handling traffic were the following stations: Ve7ACW, 7PY, 7CX, 7KE, 7SW, 7PO, 7AAZ, 7WP, 7DA, 7FB. Many thanks to the Ve6's and Ve7's who let us use their frequencies and to any others that we may have left out of the roll call.

Information regarding all active Canadian nets will be appreciated.

C. & U.S.R.S. COLUMN

By Sid Prior

Good December, my friendlys, and how is the S.W.L. contest coming on in your shack? If by chance you missed seeing the rules and regulations, turn back to October issue of XTAL and you will see there is lots of time to get in, and have a lot of fun this winter with a chance of winning one of the prizes which I will be telling you about very shortly.

Since Nov. 1, the start of the contest, 10 and 20 has been very spotty as far as dx is concerned. There has been some short skip and the S.A.'s and W6's have rolled in, but with the winter coming on dx should get better.

Have had a couple of nice letters this month, and one is from Cyril Wallis of Lansing, Ont. He listens in on a Super Pro 400x and a H.F. 10-20 converter ahead of it. Cyril is putting up a Hammond Beam for 10, so SWL for him is going to be a treat.

The other letter was by carrier pigeon and in it was some choice QRM about the boys in the Upper Canada College Radio Club, so I will spill it:

Gordon West, "Bill", is the secretary and a CAROA member, and keeps out of trouble listening in on a 19 set on 75 and 80. Bill is quite old, all of 15 years.

John Dick, 16, is the treasurer, and has engineer's papers to operate a 19 set on 75 and 80.

Dave Bowden, all of 17, we think, is the big noise up at U.C.C.R.C., as he is the president, and he too manipulates a 19 set on 75 and 80.

Now there is just one thing we all want to know. Did you fellows put in a bid to the Canadian Army to buy up all the 19 sets available? All kidding aside, I like to hear from all you young gaffers, so carry on, young Canada.

So save anybody interested a lot of trouble, I may mention an incident that happened to me:

I was interested in securing a surplus P.E. 103A Dynamotor at \$9.95 from St. Louis, Mo., for the club to use as an experimental supply for mobile work. In accordance with our Department of Trade and Commerce, I sent six copies of C.G. 101 and the necessary letter, etc., to secure permit for import. In answer, I received a letter dated Nov. 8 to affect that we regret, no soap, etc., foreign exchange, (\$9.95), so, fellows if you are looking through a U.S. catalogue and see a choice surplus item, just forget it.

So, gang, as this is December and Xmas very near, may I extend to each one of you my personal best wishes for a very Merry Xmas, and a happy and prosperous dx New Year, and I hope you all get that something for the shack.

Till January and the new year 1949—73.

Meet Your Friends At The

SCARBORO A.R.C.

ANNUAL BANQUET

AT THE Y.W.C.A.

1152 Gerrard St. E.

Saturday, Jan. 29

TURKEY DINNER

ENTERTAINMENT

PRIZES

Registration Starts 3 p

TICKETS: \$2.75

C A R O A

CLUB ACTIVITIES

The **Radio Club of Quebec** (Quebec City) recently elected their slate of new officers. M. Drolet, Ve2OF is president; C. Prince, Ve2AC, vice-president; Marc Cimon, Ve2WH, secretary. The directors are A. Duberger, Ve2HB; Felix Edge, Ve2QN, and Claude Dostie, Ve2ZN. It is reported that an interesting program has been planned for the club season. Most interesting, during these days of rising prices, is the fact that they have reduced their dues from three to two dollars. CAROA wishes all of you fellows a most successful club season.

The new season is well under way at the **Calgary A.R.C.** Code classes are held for 14 budding hams. The annual banquet is the highlight of December. Assistance is being given a radio club at Crescent Heights high school.

This year the **University Amateur Operators Association (Ve7ACS)** has 45 members, and of this number 20 are licensed. The majority of the members are studying engineering, so keep an eye out for their rigs in the future; they should be beauties. The club has two transmitters; one 500 watts on 10 phone, the other 200 watts on 40 and 20 CW.

During our summer vacation from school the club was active in flood duty. Many of the gang ran communications for two solid weeks. They returned from this duty on a Friday and on Saturday took a busman's holiday by going on a field day up Burnaby Mt., where they worked 80, 40, 20, 10, and two rigs which were powered by a portable generator.

The club is actively preparing its new members for writing their tickets. This program includes three code classes and one theory lecture a week, as well as the construction of a two-tube receiver.

At **Carleton College, Ottawa**, an amateur radio club for student amateurs and those interested in obtaining a license has been formed. Starting with a membership of fifteen, including five licensed members, the club hopes to have a station on the air under the club's call which is to be allotted soon. The executive elected is as follows: President, D. R. Burrill, Ve1FV; secretary, T. Le Grand, Ve2BAY; treasurer, K. Dowd. Correspondence and QSL's should be addressed to **Carleton College Amateur Radio Club, Carleton College, Ottawa, Ont.**

The **Sudbury District Radio Club**, after a layoff during the summer months, is again in full swing. The club has recently acquired permanent quarters and the members have been kept busy altering the building and setting up a No. 19 set recently purchased. On Sept. 27 a new executive was chosen for the 1948-9 term. The following are the new officers: President, Jack Rumball, Ve3BUS; vice-president, Jeff Hervey, Ve3ATM; secretary, Ross Parker, Ve3AZF; treasurer, Phil Empey, Ve3AYO. The club has 17 licensed members, and 12 associate members. The licensed members are Ve3AYY, AYO, BEK, BVH, BUS, ATM, AMV, AXE, AKD, BBC, AOG, BOH, AZF, ARG, BZN, AEZ, and BLZ. The club has applied for a station license, and will be on the air soon. Commencing Friday, Oct. 22, the club bulletins are being transmitted on 80 meters by one of the members. This is to continue weekly, it is hoped. Plans are also being made for the local transmission of code practice periods at frequent intervals for all those in the club and others who might be interested.

The **Westham Radio Club** is the newest amateur radio organization in Ve2. The formation of the club began in September and six meetings have already been held. The organization is comprised of members residing in the Notre Dame de Grace area of Montreal, the city of Westmount and the town of Montreal West. Meetings are held on the first and third Wednesdays of each month. Club dues are \$2.50 per annum. At the Oct. 20 meeting, Bill Pentney, Ve2JJJ was elected as president. Ross Way, Ve2WY, was chosen as vice-president and R. B. Stewart named the secretary-treasurer. The club members state that the prime aim of their organization is to get to know the fellows in their district better by adopting a more sociable type of program than that found in large club groups. Also of great importance is their desire for a small executive and a minimum of club business. Indicative of their aim in minimizing club business may be observed from the fact that all organizational business, including their by-laws, have already been completed. Those wishing to communicate with the Westham Radio Club, are requested to direct their correspondence to R. B. Stewart, 418 Claremont Ave., Westmount, Quebec.

Kirkland Lake Club sends code practice transmissions on 7139Kc at 2015 EST, Monday through Friday.

We are advised of the election of officers by the clubs listed below:

British Columbia A.R.C.—Pres., Reg Town, Ve7AC; vice-pres., Ted Hird, 7AGZ; sec., Pete McIntyre, 7JT; board members, Shirley Craig, 7FY; W. J. Summerby, 7ABP; W. S. Cringan, 7WO; Bill McCarter, 7FAC.

Penticton A.R.A.—Pres., Dud Hatcher, 7FD; Vice-Pres., Wilf Moorehouse, 7US; Sec.-Treas., Lyle Brock, 7YE.

Vancouver A.R.C.—Pres., King Cavalsky, 7AL; Vice-Pres., Ralph Norman, 7ID; Sec., Ernie Steward, 7AAX; Treas., Jack Morrow, 7RF.

The Victoria Short Wave Club held their annual meeting on Nov. 12 at the clubhouse. Officers elected were: H. R. Hough, Ve7HR, president; D. Scholes, Ve7DY, vice-president; Alan Pratt, Ve7SW, secretary; E. S. Cross, Ve7IE, treasurer; W. Paret, Ve7AM, and S. M. Jones, Ve7XX, board members. Retiring President D. Vaughan-Smith, Ve7EP, is the Plans were announced for the club's annual remaining member of the board of directors. hamfest, held this year at Lougheed's Hall on Nov. 27, afternoon and evening. Renovation of the clubhouse is included in plans for this year's activities, and may include completion of the floor, painting of exterior (porch is done), replacement of window panes (one completed), cleaning up of grounds, repair or replacement of masts, installation of sanitary facilities (incomplete at present). Club now publishes a monthly bulletin, which is expected to be self-sustaining by the next issue.

From RF, the club bulletin, we learn that the Southern Alberta A.R.C., Lethbridge, held its election of officers, and the boss men for the season are: President, Walter Jordan; vice-president, Bill Anderson; secretary, Murray McLeod; editor, Bernard Clancy.

In the bulletin of the Frontier Radio Assn. it is noted that a special effort is to be put forth in getting young fellows interested in ham radio. A program of code practice and theory instruction is being planned. This field of activity, so peculiarly belonging to clubs, is becoming more noticeable, and should be exploited by still more club.

For those who hold that Kelowna, B.C., is inaccessible by radio, the Orchard City A.R.C. advise traffic for that city may be routed via Ve7ND at Vancouver or via the 7 a.m. net through Penticton.

B.E.R.U. RESULTS

Results of the 1948 B.E.R.U. contest are now to hand. Mention is made of the increased response from Canada and we hope that it will continue to grow.

In the senior contest, VK2EO was winner with 2,914 points. Ve's finished as follows: 21st, 3KE, 1696; 41st, 1CU, 1209; 48th, 1EK, 972; 49th, 1HG, 924; 51st, 2BV, 913; 52nd, 1EA, 887; 58th, 3VN, 799; 64th, 6MZ, 755; 66th, 3ADV, 722; 68th, 2OI, 700; 70th, 1RP, 694; 75th, 1IM, 631; 77th, 5AT, 573; 79th, 3QB, 548; 81st, 1NE, 526; 85th, 3AFY, 407.

Winner of the junior contest was ZE2JV, with 1709 points. Ve5QZ was tenth with 811.

Several Canadian scores were disqualified for lateness in return and for not using official forms, which were available at CAROA HQ. Among them were 3BBR, 1,333; 8NX, 75; 1KN, 1,084; AKG, 912; 2WW, 2,611; 6IZ, 204; 1PQ, 692; 1BV, 1272; 3AGZ, 620; 3ANO, 563; 3DU, 166; 6AB, 131.

Check logs were sent by 7AQ, 7QZ, 2RL, 3AAW, 3ACS, 3BWY, 3DT, 4EO.

The dates for next year's B.E.R.U. tests are March 5-6 and 19-20. A supply of entry forms will again be secured by CAROA, and will be forwarded on request to any Ve.



Those seeking information on folded dipoles using twin-lead should write Amphenol, asking for Amform 1457-6815.

For hams converting war surplus equipment a tube designation chart is invaluable. The R.S.G.B. has compiled such a book, "Service Valve Equivalents." It is obtainable for one shilling at R.S.G.B., New Ruskin House, Little Russell St., London WC1.

At last ye editor has seen a vernier scale which can be read. Whilst visiting 3GH saw one on his HRO, and while at first glance it may seem superfluous on the HRO dial, five minutes' use convinces one of its value. Vernier marks a quarter of an inch apart!

WARNING

To the bootlegger using the call of Ve2SC, Chuck is mad enough to organize a posse and hang from the nearest beam boom the fellow using his call on ten phone. He works 80 CW only, and will not reply to the scads of dx cards for ten he is receiving.

DX NEWS OF THE MONTH

By R. D. Carter, Ve3QD

This month we are starting our column with conditions on twenty at a new low. Instead of improving, dx seems to get more scarce each day, and if it doesn't pick up soon CQ's contest will be a great disappointment to us all. Ten is picking up a bit and some nice QSO's have been made and a good share of real dx has been worked by the Ve's. It's not as steady as last year, though, and signals drop out very fast at times. Forty is on the upgrade and should be the best bet for the next six months. Eighty is still uncertain, though the odd one has been reported. What is really annoying is to hear the W3, 4 and 5 boys still working stuff that isn't audible here. Guess we'll have to move south.

Now for the mail bag, and we are glad it's a bit heavier than last month. The Hamilton Amateur Radio Club send me their monthly bulletin and it's a nice effort and covers the activities of the local gang on all bands from 80 up to 2 meters. It's nice to see such activity from my original club. 3BNQ added VP5PRD, VQ2DH, IS1AEX, XZ2KN, VU2GB and MB9AD. 3BHS works HL1AE on 20 with 60 watts and is very happy. 4RO is back in business again and our congratulations to him on obtaining his WAZ. Herb Becker was tough on his country list and removed several well-known pirates, but George just sat down and worked IS1AHK, VP2GJ and AP2F to partially offset the deductions. Tough luck, OM, but

Station	PW Total	Zones	1948	
			Total	Zones
4RO	161	40	123	
7HC	160	40	133	40
3QD	174	38		38
VO6EP	131	38		
3IJ	132	37		
2WW	122	37	117	35
1PQ	112	36	61	
3AGC	124	35		
3ACS	103	35	49	22
3AVA	103	32	66	23
5JV	84	31		
1NE	91	32	91	32
3PI	83	28	74	
10M	79	27	70	26
8AS	55	26	20	15
5QZ	54	26	48	25
3QE	55	24	51	23

1EA 120, 3AAZ 118, 4XO 108, 3AAX 102, 6FK 93, 3BWY 81, 3BNQ 81, 7EH 77, 3TB 75, 3LJ 72, 3BBN 70, 3AGX 66, 3QB 61, 4RP 61, 3BNL 52.

we've been through the same thing ourself and know how you feel. 4XO is up to 108 countries, all on 20 with a zepp antenna. Nice work, Chuck. 3AGC has a 4-element up on 20 and broke it in nicely with VP6PX, I1BCB Trieste, KX6AF, HDPP (Galapagos), CZ2AC (Monaco), FE8AB, C1RO, J2AAA, TA3FAS. A swell start, Cam. 3BNQ snared VQ5PBD and KA1VVS. Al is hard after TA3FAS. 5JV QSO'd HA, CR7, EA7 and YR5 and is looking forward to some good dx on ten. 7AFI got VR2BD, VK9RC, KJ6AB, as well as ZL, XE, KH6 and KL7 on 40 and VS6AZ on twenty with his 30 watts. Harry also now has his WBE post-war. A fine achievement with such low power. 8AS has moved and not yet fired up but with a new HQ129X and a new VFO building should be all set soon. 10M adds VP3ACS, CR9AQ and YN1OC and reports a very pleasant visit to Ve3 land this summer. He also says that three of the Halifax dx men are off the air at present but can't take advantage of it as conditions too poor. 5JV keeps up the good work with OE1CD, FE8AB, FO8AA, PY3CH, IS1AFM and VP2GJ and is disappointed with ten. 3AGC gives us the gen on HDPP, who is Len Henson, c/o Columbia River Packers Assn., Astoria, Oregon, and who works on land on one of the Galapagos islands in conjunction with the tuna fleet. He has also handled a number of Ve QSL's for TA3FAS, so be patient, you who need that card. He received a card from EZ4X and wonders where he is located. In a QSO with him he told me he was undercover in Germany, so don't count that one, Cam. 5QZ has moved his QTH and is now living in a government house and anxiously waiting for permission to operate a station from it. He was high Ve on 40 meters in the 1947 VK contest, and our congratulations, Cliff. As the new house is some distance from the hangars he is expecting the reduced QRM will help a lot. A 3-element 20 and a 4-element ten now building will help also. 7HC is back to civilization and working hard to get everything ship-shape for the contest and coming season, and just to warm things up got on 80 and worked LU7AZ, which makes 5 continents on that band. On 40 he added a few Europeans and on the old reliable 20 really went to town with FI8ZZ, ZC1CL, VP8AJ (Antarctica), YS1PB. Looks like everything is perking OK, Gord, and be hearing you. 4RO finally got himself a new receiver, a BC312, but is unhappy about the lack of band-spread. You'll still be using

Introducing Your D.R.

A. A. W. SPALL
Ve8AS, ex-Ve3AR

Back in 1932 someone told me about these new fangled short wave receivers, so purchased one within my means (\$8). The man who sold it to me said it would work, but I must have hooked something up wrong, because all I did was blow the tubes out. This made me mad, so decided must know more about the whys and wherefores of said contraption.

Shortly after happened to read in the Evening Telegram about the club meetings being held at the Royal York each Sunday, so hopped a street car to see what went on here. I met a bunch of fellows who called themselves Hams and who not only knew all about the short waves but who used them to talk to one another. There and then I decided that's for me, so went home and spent all week memorizing the code and reading a book (ARRL) on ham radio. Winter came and spring was around the corner when I journeyed to see the R.I. A few weeks later my licence and call Ve3AR arrived. During the period of waiting I was busy building my xmtr, a 45 TNT, and an off-center fed Hertz antenna (never liked them since). On March 12 cranked it up and emitted an RAC note on 7 Mc. Weary hours later Ve3EM answered my call and we both enjoyed our first contacts. The single 45 soon gave place to PP45, then a MOPA. Crystal control was becoming popular, and in 1935 a Bliley xtal was purchased and necessary doublers, etc., with an 830 final, class B mod. with 210's. This rig with a vertical for 20 and zepp for 40 and 80 meters did yeoman service till the ten-meter bug became active. Another 830, later replaced with a 802, was used as dblr to ten. Among the first Toronto stations on ten, WAC was accomplished, but because of lack of the VU card was never confirmed. Outbreak of war closed down Ve3ER, who later joined the R.C.C.S. and was sent to present QTH of Whitehorse, Yukon.

the FB7, we'll bet. George took a crack at the fone contest but says conditions were poor, and that was our observation here from spells of monitoring the bands. 3BBZ is now 3PI, and you should see the swell new 45-foot tower that he put up to carry the 3-element 20 and 5-element 10 beams. 3IJ adds YS1PB, EA9AI, IS1AHK, VP3KM, ST2GH, CR6AI, C7AT and HL1BA, who is returning to the States and will QSL all when he arrives. Harry is still watching the mails for his DXCC certificate. Congratulations to 3BWY for being No. 14 to receive the Empire dx certificate. This represents a real achievement, as the number of countries required must be split between different bands and the same country doesn't count more than once. That's all for now and hope next month to have some dope on the contest for you. Contributions to Roy Carter, 304 Brookdale Ave., Toronto 12, Ont.



With the cessation of hostilities ham radio bug began gnawing, although the XYL and two daughters figured I must be crazy to fool around with all that voltage. Some time later a crystal-controlled rig with a 250TL running 800 watts class B mod. with 805 began pushing out the RF under the call of Ve5TC, later Ve8AS. The 250 proved hard on the power (20 cents a KW), so a new rig using VFO 807 buffer-doubler and PP 813 final with 750 watts input replaced it.

WAC was worked in a few months on 20 fone with RST 59 reports. So far a total of 54 countries and 26 zones have been ticked off, which is still behind our pre-war total of 82 countries and 34 zones. Plans for the future call for a move back to Ve3 land. The frozen north is O.K., but for my money the Indians can have it back. Picture enclosed was taken with the thermometer at 62 below zero.

In response to our request for a list of 25-year hams, three prospective club members have already filed claims. How many more charter members can we find for quarter-century club?

So I added NBFM to VFO

By C. M. Fockler, Ve2VL*

I found that phase modulation very simply and economically can be added to the VFO described in September, 1946 QST, page 13, by making a few modifications to the output stage.

These changes are shown on the diagram. The plate circuit must be triode connected, and a tuned circuit incorporated with output on the 80-meter band. This results in greater output for driving a doubler stage and many of you have probably already modified the output stage to a tuned circuit. There is ample

signal on the band you are going to operate on, and then making checks on the air. Experience will soon tell you the best setting for each band.

This same circuit can be incorporated in any VFO, or a separate stage of the same circuit could be installed between two stages of your present rig if necessary, and works equally well with xtal control. On the air contacts have proved this circuit to give excellent results, comparable to AM, and free from BCI of the blanketing type.

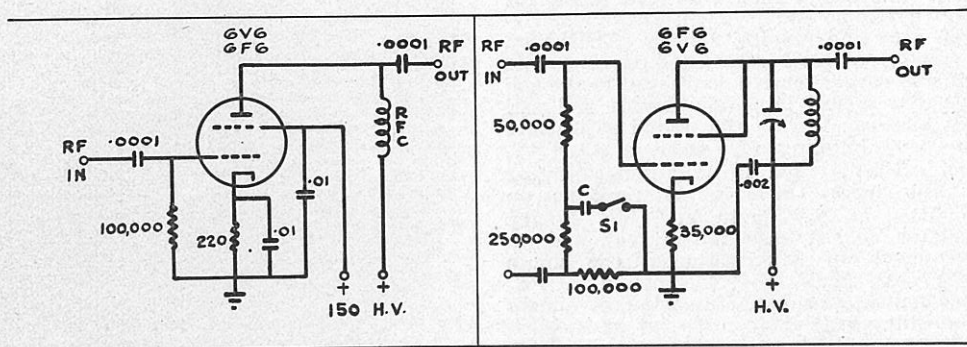

room for mounting the coil and tuning condenser under the chassis. The knob for adjusting the tuning condenser can be brought out through either the side or top of the main chassis. The condenser marked C serves to reduce the deviation of the higher audio frequencies in order to obtain a flatter audio response, as it is a characteristic of phase modulation to have greater deviation as the audio frequency is increased. It may be necessary to experiment with value of this condenser in order to obtain the best results in each individual case. A value of .002 is recommended, but in the writer's case a value of .0004 was found to give better results on 10 and 20 meters. It is not possible to get sufficient deviation with the condenser in the circuit when the output from the transmitter final is on the 75 meter band, therefore switch S1 was incorporated to remove the condenser from the circuit for operation on this band.

The audio power can be taken from your present Class B driver stage, or could be taken from the output of your receiver, using the receiver audio system as the speech amplifier. It takes only about 1/2 watt of audio power. The deviation is controlled by the gain control, and can best be set by listening to your own

* 1118 Elgin Terrace, Montreal.

Technical Articles

XTAL is pleased to publish technical articles of general interest. We are able to present some this month because they were contributed to the association. If you like them, and want to see more, ask every experimenter you meet to send to XTAL articles on his developments.

LAPEL BUTTONS For CAROA Members

Do you know that any member can obtain one of these handsome buttons by merely writing to HQ CAROA, 46 St. George Street, Toronto and enclosing postal note for 75c. We will send immediately your own CAROA lapel button.

NOW IN STOCK—NO WAITING

Identify yourself at Hamfests, outings, etc., in the coming season.

SEND FOR ONE NOW

C A R O A

NATIONAL REPORT

Ve2

Floyd G. Gribben, Ve2XR, D.R., Quebec, 5120 Westbury Ave., Montreal, Quebec. Phone EL 5387.—Let's prop our feet on the operating desk and see what's been doing around Ve2. DI, of Longueuil, has 12 watts input to a Marconi trans-ciever on 80 CW and is getting used to his new bug. AEH of Beloeuil Station bangs away on 80 with a 19 set and joins the Quebec Practice Net each Sunday morning on 3570 Kc (best 19er I've heard yet, Pierre). AIB of Roberval and Sillery, before he left for the high seas, used 25 watts on 80 CW. AK of Waltham modulates two T-40s with TZ-40s on 80. He's got a doublet antenna fed with twisted-pair that's 70 ft. high! BP of Aylmer runs 150 watts on 80 phone. His bedlam box is an S-20R. YE of Montreal runs 150 watts to PP T20's on 80 phone connected to a half-wave wire. His phones plug into an HRO. WY of Westmount put in T match on his 3L 10 beam so's he could use the new Hammond co-ax line he won at the convention. Ross also put in two new G.E. selyns that he also won. JJ got very unwelcome QSL from his landlord about antennas. Now Bill is using a folded dipole for 10 in the back porch. (Any antenna farms for sale cheap?) AHV is a new fist heard on 40. AGA is also a new ham. He works 40 from Valleyfield. Paul uses 80 watts on 807's into a half-wave CF antenna. AFI is a new one on 80 CW. NA, QJ, ACN and AEO are also banging it out on 80 CW. JD carts his rig back and forth between Westmount and St. Sauveur so's he can take to the 20 meter air on week-ends. Jim modulates an RK39 with 6L6's. He doesn't transport the antenna too, though! He has 8JK beams at both places! AEG of Montreal left 2 for 10 and runs 25 watts to an 807 linked to a folded dipole. He hears the gab on a BC454 with a R1151 British Marconi converter. LM of Montreal gabs on 2 with an SCR522. VL does the same with a 19 set in his car. AEL of Montreal rigged up a J antenna for 2 (can you work J's with it, John?). AEJ of Montreal plays with a 19 set on 2 and Ed uses a dipole on it.

AFV of Westmount uses a ground plane antenna on 2 hooked to a 19 set. FO of Montreal was heard in Vermont on 2 using 40 watts of FM from a Sonar exciter. FF of Montreal tore his 19 set asunder and made a new rig and receiver from the parts. YW, who used to be Ve3BCU, of Kingston, puts Montreal West on the map with an SCR522 and a dipole on 2 meters. ZD of Montreal is QRL building a console control desk for his 813 rig on 40. Bus hears the stuff on an R1155. Once again, after a short absence, we hear from our Quebec reporter, GF. Rosaire has this to say. PM got back on the air about the middle of November. ZU skeds IP and AO of Montreal on 80 CW. (How about looking on 3570 Kc for the Quebec Practice Net on Sunday mornings, boys?) We hear that GF accused the R.I. (in error) of being a bootlegger (over the air!) GF very active on 80 CW with 18 watts and helping a few new boys to get started. ADF moved to Port Alfred, Lake St. John County, from his old spot in Quebec. AOF is heard on 40. AIH and AIJ are new Quebec hams on 80 CW. (Thanks for the news, Rosaire OM). GM of Longueuil has been QRL organizing the Quebec Practice Net (QPN) on 3570 Kc on Sunday mornings. He's looking for newcomers who would like to learn traffic handling. Get in the fun, fellows. If you're interested, call GM on that frequency or drop him a line. Bert Altherr, Ve2GM, 268 Guilbault Ave., Longueuil. GM, NR, XB and XR took part in the Simulated Emergency Tests in October on 80 CW. In spite of the small turnout (typical of Ve2, darn it) a fair number of messages were relayed to BB, the Section Emergency Co-ordinator for Quebec. BV is a new ham in Nitro, having been Ve1AQ from Lakeburn, N.B. Welcome to Ve2. OM. XL moved from Dorval to Ville St. Laurent and his 20 phone took on a new set of BCL's. DL of Montreal, our Montreal area CAROA OBS, finally gets back in time for Christmas after an over-long business trip in the Maritimes. We missed your broadcasts, Rene.

AIA, formerly Ve3AAN of Sarnia, Ont., is now cosily located right over QQ, who's in the apartment below! WK and XR of Montreal are right next door to each

other, too! In fact, neither one knew about the other until they QSO'd on 40! LS of Verdun uses 807's on ten phone. Our Drummondville reporter, LO, sends us his usual, reliable monthly letter. John says his 730 a.m. skeds with Ve3WK and WILM are perking up in QSP's. He says he's finishing off a new VFO. He goes on to say that AAG, also in Drummondville, is going great guns on 40 and 80. TD of the same town returned to the air with 300 watts after a long silence. AA wants to get on phone from Drummondville. He has the parts but not the time to hook 'em up. The telephone company in Drummondville has asked the local boys there for co-operation in the event of an emergency. LO accepted and is hoping to line up a few more of the local lads there for this work. Thanks for the news, John. ACK of Verdun and his 60 watts to the 807 finally got over to W land on ten phone. CB of Verdun should have his new 3L C.S. 50 ohm co-ax fed beam in the air by now. At the October meeting of the Montreal Amateur Radio Club, the convention committee officially bowed out after a year of real hard work on the convention. The chairman, Herman Eberts, Ve2XP, gave the meeting his final report and thanked all his colleagues for their splendid year-long support. He said that in spite of the many things that happened to change the financial picture of the Hamfest, the club came through with only a 3 per cent deficit! All in all, a swell job well done! At this month's meeting there'll be the usual December prize draw financed from club funds. There'll be three prizes instead of just one this year, though! Last year there was just the NC-173.

BEEF DEPT. . . . There's not enough Ve2 traffic and emergency operators! As a radio amateur, is your existence justified by the service you have to offer to your community? Basically, amateur radio is a hobby, but as our numbers have steadily increased, we have found ourselves more and more depended upon by the public. The many thousands of amateurs who served in the services during the war, definitely gave amateur radio our much-wanted recognition. However, let us not be satisfied to rest on these laurels. Let us continue to serve here at home to enlarge and strengthen the prestige we have received. When the need arises to serve, be it a local or national emergency, or the handling of personal messages, are you, as one of us, able to do your part? If your answer is "yes," you are an exception to the rule and a worthy addition to amateur radio and your community. If your answer is "no," then shouldn't you do something about it? If you're like most amateurs, you're not quite sure of the first step to take to really do something. Perhaps this may help. May it be suggested that you carefully read the chapter on message handling in your handbook. When you have thoroughly absorbed the procedure to be followed, turn to the chapter on emergency work and read carefully. Upon completion of your perusals, get in touch with your A.R.R.L. Route Manager, Section Emergency Co-ordinator or the Section Communications Manager and ask for further literature on traffic handling and emergency work. While you're at it, ask him to advise you on where you can obtain some practical experience. He'll be glad to help you out. Most likely he will direct you to an existing traffic net. Then you should do a lot of listening to study the net routine. When you have an idea of how things work, get in touch with the Net Control Station. He'll be glad to fit you in with the boys. If you should hesitate to proceed along these lines because you feel you're not a traffic man, then let it be known that experience isn't necessary! Just your interest! You'll meet fellows, who, like yourself, are willing to learn to be of service to their community. If you don't think it's fun and a great change from the monotonous QSO operating you are now doing, then ask a fellow who is engaged in this work! Get in touch with your Section Communications Manager, G. A. Lynn, Ve2GL, c/o Radio Division, Montreal Airport, the Route Manager. Tom Stacey, Ve2XB, 713 Rielle Ave., Verdun or the Section Emergency Co-ordinator, Ve2QQ, R. K. Grant, 72 Hudson Ave., Mount Royal. Then get going, fellows! There's a great need for traffic and/or emergency operators in this province! We are lagging behind the others, so wake up, Ve2! Before I sign and close my last column for 1943, I would like to take this

opportunity to thank all of you remotely located fellows who took the trouble to drop me a line each month with the news from your locality. I would also like to thank those who phoned me their news, gave it over the air, or answered my many inquisitive questions in personal interviews. Your much appreciated contributions have made this column possible and worthwhile. I only hope that in 1949 I can count on your continued support. So, until next year then, a Happy Christmas to all readers. See you here in 1949! 73—Floyd.

Notre chroniqueur français: Marc Cimon, Ve2WH, 2156 Blvd. Laurier, Québec. Tel.: 7-1168. Parmi ceux qui lisent ces lignes, il y en a sans doute qui m'ont déjà écrit et qui se demandent comment il se fait que les nouvelles qu'ils m'ont envoyées n'aient pas encore été publiées. Je vais vous l'expliquer. Nous sommes actuellement en décembre et cet article a été écrit à la fin d'octobre. Et il en est de même chaque fois que ce compte-rendu est imprimé dans le XTAL. Alors, prenez patience et soyez certains que je ne vous oublie pas et que votre tour viendra. La Convention de l'ARRL à Montréal a été un franc succès et tous les OM's qui y sont allés n'ont pas regretté leur voyage. Ceux qui passent par Cap-de-la-Madeleine ont l'occasion d'admirer le nouveau 'beam' de TR. Il est visible à plusieurs milles de distance. Attention! UD de La Malbaie et UI de Montréal opéreront bientôt respectivement un pp813 et un pp810. Ils manifestent toutefois le désir de demeurer en CW. Hi! ACC de Chicoutimi emploie un appareil 19 Mk III et se promet d'être très actif. De même AHG et AFO de Québec sont nouveaux venus et espèrent établir beaucoup de contacts. TO et FM de l'Île d'Anticosti sont entendus régulièrement sur 75. ABC a mis un pp826 en opération et obtient des résultats épatants. TC a transporté son qth de Rivière-du-Loup à Montréal. AAX, IW et AFC tentent leur chance sur 10. YD est très actif le matin. Pour le rencontrer, il faut se lever de bonne heure! hi!—C'est tout pour ce mois-ci, les amis; je vous invite à me donner de vos nouvelles et souvenez vous que cette colonne vous intéressera en autant que vous y apporterez votre collaboration. 73—Marc.

Ve3

W. Bert Knowles, Lanark, D.R.

The last day of the month has rolled around again, and that means your DR starts to read a month's reports to find the dope for this column, and as we write this, on our holidays in Kirkland Lake, the reports are very few. AUI is trying two meters with a two-element team and an 815. HG has 57 countries and is waiting for one card for his WAC. NI is back on the air again after a sick spell—the gang sure missed you. You can't keep a good ham down, as note the report on GG for the past couple of years—April 11/47, broke both legs riding a motorcycle; Oct. 4/47, back to work; Jan. 30/48, broke leg again, at work; May 3/48, broke same leg turning over in bed; Oct. 25/48, walking around hospital in iron brace. We all hope you are soon home again and have no more accidents. Are ADM and LZ going to have some other attraction than ham radio? MI stayed with 2XR while at the Montreal Convention. 3HB motored home from convention via Ottawa and Lanark. BBM has a new bug and along with BCJ hopes to be on 75 fone soon with a No. 19. DD, XO and W1DQX visited your DR. Your DR while going to Kirkland Lake for holidays stopped at various places along the route and dug up the lowdown's. PEMBROKE—NY is engineer at CHOV. Bill Pilot has a 19 set and will be on the air soon. Harold Price, 3AEQ of 1921 vintage, says he is going to come back on the air, and has joined CAROA. DEEP RIVER—IN recorded voices broadcast by ARX (club station) at community hall and played them back to the producer. The Deep River Radio Club has about 30 members, with the following licensed hams: BPV, IN, AAG, ABF, BDO, and VS. ATY and AAG have joined the ranks of the benedicts—another two hams lost. At North Bay BBM met your DR at the station at 0630 hrs. API is putting up a four-element 20-meter beam on 35-foot poles. PH is in Ottawa attending a convention. PA has a four-element beam on 20. DAD is flatfoot No. 10 in Kirkland Lake. EAA is another new ham in K.L. and has a nice layout with an 807. WI has moved to Larder Lake and has a swell layout in a room devoted entirely to ham radio. The Ontario Phone Net is in full swing on 3815 and is doing an fb job, but at times is badly QRMed, we hope unintentionally. Please, gang, watch that freq. Monday through Thursday and keep away from it unless you want to join. As a final word of warning, there is a heavy penalty for intentional QRM, and don't for one minute think that the D. of T.'s monitoring stations don't listen on the ham bands. Similarly, the area fone net of AFARS on 3755, and the

Ottawa Valley Net AFARS on 3835. How about some member of the Beaver and other nets sending us a list of members and activities. Don't forget the Ontario Phone Net "Food for Britain" fund. The need is still great and your donations may be sent to either Mrs. C. E. Lloyd, 26 Dixon Ave., Toronto, or to the Ve3 QSL manager. There were only 1,054 QSL's received at the Ve3 QSL bureau in October. ATR complains that the Lanark postmaster hits the stamps too hard, and ruins them for collecting purposes. You're not the only one, Bub; have had the same complaint from VK, G, and others. The Ontario 40-meter net is in need of more members. If interested get in touch with ATR. 3AOK has moved to Windsor. XG and family spent vacation in W and saw lots of 10-meter beams. Our thanks to Northland Radio Supply for use of typewriter to make out this report. ADN is operating on 75 fone again. AXP is on the simulated emergency tests with 20 watts. How about some more of you fellows getting on the AEC? In closing this report I would like to wish you all a very Merry Christmas and Happy New Year with lots of dx.

73—Bert.

Ve4

Les Saul, Ve4FJ.—Things are starting to pick up around this neck of the woods now, and with 20 getting back to something like normal, activity in that area is good. 4NI is now using the VFO described in August QST and says its a fb rig all around. EA is pouring out a husky signal on 20 these days. QV has new 66-foot tower for his beam and feeds it with that new 90 ohm twin co-ax. Don's getting S9 plus reports from B.C. off the end! A Ve8 really thought QV was a newcomer to 20 following a rib session with 7ZZ, 7OT and 4NI, and Don was forced to hurriedly correct this impression, hi. In a recent round table, QV, 7OT and 7ZZ all got an S9 plus report from Ve8. Expect 7OT to visit Ve4 one of these days. 4HU, in a QSO with a W, told him that he seemed to have a bit of trouble in his modulator since he had already blown two fuses and was using his last one. About that time he went into a description of how his 866's were flaring up and a moment later out he went. Guess the fuse blew. At the end of October the Ve3's and other eastern points were hitting Ve4 S8 to 9 at regular intervals. HB is busy buying parts for a new exciter—for 40, of course! Harry is a confirmed CW man. 4AB has put up a 16-foot vertical on his house, a War Assets tank antenna, and uses it for receiving only. Tex claims that it's doing a wonderful job, cuts down ignition and diathermy noise 80 per cent. 73—Les Saul.

Ve5

George Cox, Ve5BF, D.R.

In making my bow as interim D.R. would like to say that if I am going to dish out the news I have to get it in, and I wish that one would make it a point to drop me a line to 237 Fifth Ave., Saskatoon, on the 25th of each month. Around Saskatoon most hams are getting all set for the winter's hamming after their various summer holiday activities.

5BW is on 10 meter phone looking for Toronto contacts to keep in touch with his friends down there. 5LG is not active at present. 5FG is constructing a beam and working on 40 CW. 5GE is on 10-20-75 phone and occasionally on CW, and now has a ten meter beam working. 5AJ has an assorted quantity of aluminum tubing and fittings spread over his back yard which should make up into a Hammond 10-over-20, together with a 35 ft. steel mast five inches in diameter at the base which is still to be raised. Looks like he will have to advertise free refreshment. He still keeps sked with ZL3AI on 20 meter CW. 5EW is working CW on 20-40 and 80. 5JC still has gear in storage, no suitable location yet. 5MQ has 120 watts, now using NBFM on 10 and 20 and getting out well. 5DR is now on NBFM fone 10 meters, and is getting out fairly well but sighing for a better antenna system. Uses pair RK39's with 70 watts input. 5OB going great guns on 10 and 75 phone with new TBS50. Getting comical quid or is it cubicle quad minded. Look out for those big winds out there, Carl. 5CR is now on 40 CW. 5FL is now a confirmed dx hound and with the three-element rotary she pulls the ZL's, VK's and G's out of the background and works them in fine style. Also snagged an HB9. The OM, 5RJ, does the rag chewing for the family. Their 25 watts is really going places. 5DO is rebuilding. 5KQ is rebuilding for 10 and 11 and will have 400 watts. 5UZ is pushing out good sig. on 10 and 75 using 125 watts with speech clipper. 5UC has not been heard much lately and understand he has been under the weather. Can we help you perk up, Cec? 5JF came back from vacation to go into D.V.A. Hospital with pleurisy. We are missing him, as he is our portable and

high frequency enthusiast. 5FD now has 10 meter beam on top of his 20 and also has converter for 10. 5CJ still active with the 807 cathode modulated, plate current going from low to high—Whoops, she's at it again. 5BF on 20 and 10 using NBFM account BCI, also account being fresh out of Class B with burnout modulation transformer. BF has fallen from high estate and put in 458A as VFO, and first thing busts into police receiver on 155.17 Mc. Has 15 watts on six to three-element rotary and looking for contacts on six. 5YF is going strong on CW all bands. 5FY is getting junk together for portable and also building up 813 final rig. 5SY now has three-element ten meter beam up; so far we believe he turns it by the sweat of his brow. No report yet on results. 5OM on 5OP both put their beams back up for 20 and 10. 5LV is on 80 phone after years of CW. Another good brass pounder gone wrong. 5CP is now in Moose Jaw going to school. 4DR from Manitoba is going to school in Saskatoon. Moose Jaw now has nice bunch of young hams or would-be hams coming along. Would like to see them at the club meetings. What say, fellas. HB is on fone after lots of trouble. HB has just retired as secretary of the Moose Jaw Club. Thanks for good work, Ken. 5OM has just got folded dipole for 20 meters. 5JS gets around to see the boys and is working out with 75 meter portable. Like to see you turn up to club meetings again Steve. Moose Jaw Club opened up again at the armouries on October 28. 5OM gets picture of himself and station in daily paper in news item about working K2UN, the United Nations Amateur Station. Good stuff, Austin, and congratulations on your election to presidency of Moose Jaw Club. Regina Amateur Radio Association activities were outlined at a meeting of the executive the other night and lectures on NBFM and radar are coming up. 5AW at Prince Albert has been inactive since last spring when he sold transmitter. At present he is putting double conversion into his AR77 and lining up a new rig with an 813 in the final. 5DA is inactive. Recently purchased a Meissner Signal Shifter, contemplating exciting separate final stages. 5DW active mostly on 75 fone. At present, commencing construction of a compact 50 watt phone/CW, bandswitching rig. 5NA recently moved from the southern part of the province to Prince Albert and is not active again yet. 5PA inactive during summer months but we are likely to hear a roar any time now. 5VB on 20 and 75 phone occasionally and now and again visits Saskatoon hams. Don't forget reports, fellows, on 25 each month, because the D.R. because of BCI and NGFM, not so good on 75 is not on that band much to get the local news.

Ve6

Bill Savage, Ve6EO, D.R., 329 15th St. N., Lethbridge. —PP is working out very fine, he now has WBE. Must be a good location for ham radio, Pere. LB is in operation and is also getting out nicely. AB finally bought a lot of postage stamps and is trying to catch up on his QSL cards. He also is rebuilding and claims is really getting nice reports with his beam. QC is a new ham heard from, tnx for the envelope, om. KE is a C.P.R. opr. at Bow Island. Nice to hear from you, Ray, and hope QSO you soon. AO says—watch out now for the rare stuff, just put up a 40-foot pole for a stacked 20 and 10-meter beam. He claims he had to do it in self-defence with all those guys like TM, GD and MZ hogging the dx. Yes, what a rat race it's going to be this winter. FK says he has reached the 100 country mark and is finding it tough to find more. RX is a new ham at Cowley and is sporting a SX32 receiver. KS now has another jr. opr., yes a 9½ pound baby boy. Well, we also hear ex-6KZ now 7AKZ also has a jr. opr. LZ is making an electronic key. We hope it doesn't make as much noise as his relays do when the power fails. Ex-6AF pays yours truly a visit, and I think he has the bug again. The Southern Alberta Amateur Radio Club had an election of officers and results were as follows: FS, president; MA, vice-president; MV, secretary-treasurer; BC, editor of club paper. MN catches a mouse in his mouse trap three nights in succession and the fourth night the mouse took the trap. Some moose, hi! YN is very busy with an extension to his house. He will be able to QSO in comfort this winter. DN gets so interested in his QSO that he burns his bacon, yes, and the price of bacon today. NO is a new ham in the southern part of the province. JD is busy on 80 CW and is building a modulator to go on 10 fone. FN is on 40 and 20 CW. HV is a new ham in Brooks and works for the local telephone gang. NF is a very busy man. He takes time out to fone yours truly while in the city. HR is building a beam and trying out his 10-mtr rig. MN is busy with his VFO and getting everything ready for the dx this winter. AA is heard on after a long silence. LL says he really has a beam that works; he now has W.A.C. and needs one state for W.A.S. Nice going, Pop. LZ cleans house once a week but has to have a rest after; it really must be a job, Al. EL has more gadgets to increase power,

his pet one is shorting out a filter choke which increases his voltage by 500. BM must be going to get up his CW when he starts talking about the Candler system. LQ says he is very busy but he is working on 10 mostly. While in the capital city yours truly paid a visit to some of the boys and was sorry time was limited and could not get around and see more of the hams. MJ was busy getting his emergency equipment ready in case it should be needed. We managed a personal QSO with WB and talked over our old rigs using 210's and DeForest Type H tubes. It seems that Wally used to buy these by the dozen at \$26 each. AL has been too busy to do any visiting. BO has a lot of credit coming to him for all the work he has done in getting the Crescent Heights Radio Club going and seems to be getting lots of assistance. AO is loaning a transmitter and NF loans a receiver to Steve so he can get a rig going at the school. AC is having his rig rebuilt. NX, now a Calgary ham, is an ex-Ve2. RA is seriously thinking of getting back on the air. FK is back home after being away for three months. GH is putting out a nice signal on ten. KX is with the R.C.M.P. CS is the club call at R.C.A.F. station, Edmonton. FH, IC, HL, KH, and KM are members and several prospective OM's are studying for tickets. The layout at CS is three AT3's, two AR88's, one SCR-522 on 144 Mc. Recruits are wanted for the Air Force Amateur Radio System. Jack McLure, BD, is Alberta Squadron Controller, Ted Hodgkinson, FH, is Edmonton Flight Leader. Squadron skeds will commence Monday, Oct. 18. Every Monday and Thursday 0300 GMT. IC is nearly ready to go with ½ KW. HL is re-organizing for shipment to and installation in "G" land next May. He wants many Ve6 skeds when he gets back to "Blighty."—73, Bill, Ve6EO.

Ve7

Ernie Savage, Ve7FB, D.R., 4553 12th Ave. W., Vancouver, B.C.—Victoria Short Wave Club reports plans for next year include repainting clubhouse, putting in a floor, and more active support of A.R.R.L. including reaffiliation. Ve7AEB, AM, AKB, EP and HR are the main support of two meters activity in this area. Ve7IE and 7FV are also interested and are at work on handy-talkies. Ve7AEB has had a successful QSO with a Duncan station over a stretch of the highway between a car, en route to 7JG at Duncan. Victoria has had a succession of gales, a sou'wester, 80 m.p.h., giving us a going over (Vancouver and South West Washington also). 7AKB's rotary, 7TZ's 80 meter doublet, 7SW's 20 meter folded dipole went with the winds. Ve7CB, Chris, and Edith are on lookout for new QTH—preferably something high but not in price. Ve7UT, Jim, up in Nelson, coming on 40 CW. Oliver Radio Club, the main highlight of last meeting proposed syllabus for those interested in the "helping hand for budding amateurs." Mr. Harding lugged in his recently acquired 19 set. He bought a new Austin with 12-volt battery for the 19. Ve7MC, Milt, and 7TZ took a whack at messing up the ozone with it. 7DB, Bill, sojourned to Van. for his third class steam ticket—returned with same. 7MC, Milt, on air again running about 6½ watts single 6L6 W6 Calif. rpt RST 599X; fb, Milt. South Okanagan Amateur Radio Club has changed its name to that of the Penticon Amateur Radio Association. Ve7HE, Ted, won Port Alberni Salmon Derby by pulling the big one out of salt chuck which gives him the big folding stuff. Ve7AOB, Don, reported adding more power. Ve7KE, Les, bound for Ottawa on postie course. Ve7DD, Cecil, has been heard on fone. Ve7ACY flown from Welles to Vancouver to enter hospital, made the front pages. Ve7ABO, Len, is back in Vancouver, and selling out for time being. Sorry, Len, let's hear you again soon. Ve7NI, the blind school, is going strong on code and theory, thanks to Army, who is completely overhauling a transmitter for us. Let's hear f'om the gang for spare operators. Ve7PO rewinding coils for 10 and 20 meter finals. Rumoured Clarence heading for super efficiency; 120 ft. of 2 x 4's looks like high efficiency antenna, not neighbours' clotheslines. 73 and Merry Christmas. gang—Ernie.

Ve8

D.R. Jack Spall, Ve8AS, Whitehorse, Y.T.—Following from our reporter, Rudy, 8BC at Bear Creek . . . A local Ve8 hamfest was held at Bear Creek with good attendance from hams at Dawson City. A good time was held by all, especially when the liquid rf was passed around. SCG is on 40 when time permits, but is kept busy playing in local orchestra. SAH awaits arrival of trans for his dynamic mike. 8AY busy putting up three-ELM beam. 8AR gets around on 75 fone. 8AM still holds the low-power record with his two watts. 8BH is projectionist at local theatre. 8AM gives the dx a break on 10 and 20. 8BF has 19 set and has been heard testing on 75 fone. 8CH has new HQ129X. 8AS QRT at present. 8AW tak-

Please QSY to page 17

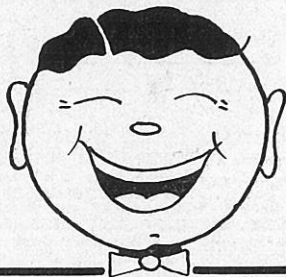

WELCOME ON! 2XR

TO THE RANKS OF AMATEUR RADIO...

Ve2ABD—J. P. Tessier, 192 Notre Dame St., Victoriaville.
Ve2ABE—J. A. Frechette, 16 Albert St., Bagotville.
Ve2ABF—F. W. Kelly, 260 Van Horne Ave., Montreal.
Ve2ABH—M. J. Lemaire, 508 South St., Cowansville.
Ve2ABJ—F. E. Thibault, 94 St. Marc St., Shawinigan Falls.
Ve2ABK—A. S. Rompe, St. Ubald, Portneuf County.
Ve2ABL—G. M. Cape, 1210 Redpath Crescent, Montreal.
Ve2ABM—W. D. Walker, 252 Wellington St. South, Sherbrooke.
Ve2ABW—H. T. Edworthy, 6560 Hochelaga St., East, Montreal.
Ve2ABX—V. M. Martinson, 3355 Barclay Ave., Montreal.
Ve2ABY—R. H. Ganong, 1084 University St., Montreal.
Ve2ABZ—C. L. Skelding, 21 Montee St., Jean Baptiste, Chateauguay.
Ve2ACB—J. A. Arsenault, 1613 Ste. Helene St., Ville Jacques Cartier.

Ve2ACC—G. Duchesne, 65 Fabrique St., Ste. Anne de Chicoutime.

Ve2ABN—A. N. Lapointe, R.C.A.F., Airport, St. Hubert.

Ve2ABO—J. L. Richards, 112 Union Blvd., St. Lambert.

Ve2ABQ—E. A. Stephens, 80 44th St., Place Laval.

Ve2ABR—S. Gauthier, 39 Fabrique Ave., Bagotville.

Ve2ABV—H. Fougere, Grand Riviere, Gaspé.

Ve2ACD—G. R. Berube, 170 8th Ave., Grand Mere.

Ve2ACE—J. B. Beaulieu, Vezina St., Trois Pistoles.

Ve2ACG—A. F. Picard, 4442 Marquette St., Montreal.

Ve2ACJ—J. Kadish, 1217 Egan Ave., Verdun.

Ve2ACK—E. J. Moore, 255 Willibrord Ave., Verdun.

Ve2ACU—R. Letts, 353 Merville Avt., St. Lambert.

Ve2ACX—E. L. Ortmeim, 3456 St. Zotique St. East, Montreal.

Ve2ACY—J. A. Boivin, 1293-B, 2nd Ave., Quebec.

Ve2ADA—A. A. Bell, Port Daniel Station, Bonaventure County.

Ve2ADB—P. D. Thibault, Pierreville.

Ve2ADC—G. McCarthy, 181 Bonaventure St., Three Rivers.

Ve2ADD—J. L. Hargrove, Masson.

Ve2ADG—J. L. Guy, 161 1st Ave., Amos.

Ve2ADH—J. G. Gibeau, 6677 De Laroche St., Montreal.

Ve2ADI—L. Desrochers, 142 2nd Ave., Amos.

Ve2ADK—J. T. Chesser, 655 25 Ave., Lachine.

Ve2ADL—R. E. Livernois, 61 St. Peter St., Ville Jacques Cartier.

Ve2AEA—E. R. Dorion, 3408 Hochelaga St., Montreal.

Ve2AEB—C. A. Norman, 527 Laird Ave., Mount Royal.

Ve2AEC—R. Beaudin, 79 Taschereau Blvd., Pont-Viau.

Ve2AED—R. S. Simard, 752 Rachel St., Apt. 206, Montreal.

Ve2AEE—O. E. Gauthier, 165 De Salaberry St., St. Johns.

Ve2AEF—F. W. Hasell, 438 Walpole Ave., Mount Royal.

Ve2AEG—S. R. Allen, 5011 Gatineau Ave., Montreal.

Ve2AEH—Pierre Gaudette, Corinne St., Beloeil.

Ve2AEI—R. L. Mullins, 1205 Mackay St., Montreal.

Ve2AEJ—E. D. Keenan, 520 2nd Ave., Verdun.

Ve2AEK—Dr. R. Veilleux, 460 Des Volontaires St., Three Rivers.

Ve2AEL—J. M. Hemmings, 2176 St. Catherine St., West, Montreal.

**LEARN CODE
this easy way**

• This automatic INSTRUCTOR machine will teach you quickly to send and receive code (Morse or Continental). It comes complete with code tapes and instruction book, gives clear signals as fast or slow as you wish. Low Rental plans, clockwork models, for 1, 3 or 5 months. New machines for sale, Electric Models included. Write for folder giving full details.

Also Day, Night and Home Study Courses in all branches of Radio Communications.

**RADIO COLLEGE OF CANADA
54 Bloor St. W. - Toronto**

Canadian Rental Hdqtrs. for over 10 Years



Ve2AEM—Rev. P. Desilets, Les Forges County, St. Maurice.

Ve2AEN—J. A. Flemming, 4180 Cavendish Blvd., Montreal.

Ve2AEO—R. L. Dullege, 3854 Gertrude St., Verdun.

Ve2AEP—F. R. Cross, Dept. of Transport, Dario Range, Seven Islands.

Ve2AEQ—D. L. Bell, c/o 426 T Squadron, R.C.A.F., Montreal Airport, Dorval.

Ve2AER—D. S. Farmer, Bldg. #23, R.C.A.F., Lachine.

Ve2AES—K. K. Strahan, 405 Mount Pleasant Ave., Westmount.

Ve2AET—Ecole Technique, 464 St. Francois-Xavier St., Three Rivers.

Ve2AEU—P. W. Berrigan, 287 Green St., St. Lambert.

Ve2AGG—John C. Cook, 159 St. Francois St., Drummondville.

Ve2AEV—J. A. Valee, 16 Prince St., Huntingdon.

Ve2AEW—B. B. Wilcox, 3365 Barclay St., Montreal.

Ve2AEX—F. W. Borrie, 65 St. Mathieu St., Ville St. Laurent.

Ve2AEY—J. Dadson, 1069 Bleury St., Montreal.

Ve2AEZ—Rev. G. J. Bineau, 250 Hector St., Montreal.

Ve2AHJ—Paul Gagnon, 559 3rd. Ave., Limoilou.

Ve2AIH—Ives Drolet, 30 Dolbeau St., Quebec.

Ve2BV—D. G. Murphy, Nitro. (ex-Ve1AQ from Lakeburn, N.B.)

Let's not forget the ladies!

Ve2AAT—Miss M. Duguay, Lighthouse station, SW Point, Anticosti Island.

Ve2ABI—Mrs. Rita Matteau, 702 6th Ave., Grand Mere.

Ve2ACI—M. F. Dufour, 575 Roussel St., Ste. Anne de Chicoutime.

Corrections: Due to a printer's error in Sept. issue the calls Ve2AGG and Ve2AHH were incorrect. They should have been AAG and AAH. Sorry, fellas.

Ve3BYG—Norman Willard Broten, 349 Thames St., London.

Ve3BYH—Richard Joseph Boutet, 44C Second Ave., Schumacher.

Ve3BYI—John Harman, 106 Greenwood Ave., Toronto.

Ve3BYJ—Peter W. Waddington, R.R. No. 2, West Hill.

Ve3BYK—Carl Clayton Read, 35 Coxwell Blvd., Toronto.

Ve3BYL—Herbert Henry Lewis, 101 St. Patrick St., St. Catharines.

Ve3EAW—Gerald Halliday, North Bay, Ont.

NATIONAL REPORT—from page 15

ing a rest now that he has his 100 countries. SBQ works 40 with an 807. SBG has new VFO. SBD still busy working on new rig. SBT has 1155 rcvr and hopes to be on soon. 8AL outside on leave. 8AK returns to Teslin after spending month outside. Understand that there are several stations operating from SNAG but have no dope on calls, etc. That's all for this month. Jack, Ve8AS.

COUPON

Please enroll me as a member of the Canadian Amateur Radio Operators Association. I am enclosing a cheque (), money order (), postal note () to the amount of two dollars which entitles me to all rights and privileges therein, and a year's subscription to XTAL magazine.

Name

Call Letters

Address

City Prov.

Licence Number

State your interest in radio if not licenced

REMIT TO: The Canadian Amateur Radio Operators Association, 46 St. George Street, Toronto, Canada.

QVE

CAROA Official Bulletins 75 Meters Each Thursday 9 p.m. Local Time

The undersigned stations have been appointed as CAROA Official Bulletin Stations. Be sure to listen for your district OBS for latest messages and bulletins of interest to all Canadian amateurs.

Ve1GD—3835 Kc—H. A. Garland

Ve2DL—3827 Kc—R. Frenette

Ve2TM—3842 Kc—Leon Baldwin

Ve3QB—3835 Kc—W. B. Knowles

Ve3CP—3775 Kc—T. Hunter

Ve4KK—3820 Kc—B. Fowler

Ve5FA—3848 Kc—W. A. G. Simpson

*Ve5GA—3847 Kc—W. T. Rogers

Ve6OD—3801 Kc—E. A. Anderson

Ve7FB—3825 Kc—H. E. Savage

Ve8AS—3820 Kc—J. Spall

*—10:00 p.m.

Ve8 QSL'S

Jack Spall, Box 268, Whitehorse, Y.T., has cards on hand for those listed below:

Ve8AA, AB, AC, AF, AH, AI, AJ, AO, AP, AQ, AR, AU, BH, BM, BO, BP, BQ, CC, CD, CI, CJ, CR, CS, CT, DR, EB, EH, EO, EW, GE, GG, GN, GO.

LW, MA, MB 50, MC, MD, ME 25, MF, MH 100, MJ, MK, ML, MM, MN, MP, MR 50, MS, MT, MU, MV, MW 25, MY, MZ.

NA 39, NB 100, NC, NE, NF, NJ, NM 25, NN, NO, NP, NQ 45, NS, NT, NU, NV, NW, NX, NY, NZ 40.

OA, OB 20, OE 50, OG, OH, OI, OJ 25, OL, OM 30, ON 0025, OQ, OR, OS, OT, OV, PH, PC 40, PL, QE, QI, TN, UR, WA, WW, OW 65, OX, OY, OZ, PA 20, PM, PN, ZM, ZZ.

No call listed has an envelope on file with Jack, so send him one and clean his files.

FOR Ve5's

The QSL manager for Ve5's holds one or more dx cards for the following. Please send in stamped self-addressed envelopes for your cards and repeat when you get your envelopes back: AW, AJ, AAQ, AY, AC, AL, AA, ADM, BW, BJ, BEA, BF, BB, CA, CF, CJ, CS, CC, CL, DW, DZ, DI, EE, EN, EM, FD, FG, GP, GG, GU, GK, GR, GI, GE, HU, HI, HQ, IS, JB, JG, JH, KI, LY, MP, MQ, MZ, MA, NZ, OF, OU, OH, OE, PE, PA, PT, PM, QT, QL, QI, RW, RC, RR, RO, RD, SJ, SW,

TV, UZ, UX, UT, VB, VJ, VD, WP, XW, XU, YI, YJ, ZM.

FRED WARD,
899 Connaught Ave.,
Moose Jaw, Sask.

QSL'S FOR Ve1's

The Ve1 QSL manager has cards on hand for the following Ve1's:

AB, AG, AH, AI, AJ, AO, AP, AT, AU, AV, AY, BB, BF, BG, BL, BM, BN, BR, BS, BW, CH, CI, CK, CM, CQ, CV, DG, DH, DJ, DM, DP, DR, DX, EG, EJ, EN, ER, EY, FG, FM, FR, FW, FZ, GB, GD, GG, GM, GN, GU.

HB, HE, HI, HO, HW, HZ, IA, IC, ID, IE, IK, IM, IO, IV, IY, JA, JB, JF, JI, JP, KA, KE, KG, KH, KJ, KK, KL, KP, KQ, KT, KW, KX, LA, LM, LV, MB, MH, MK, MO, MP, MX, NI, NJ, NK, NL, NR, NT, NX, OA, OG, OH, OP, OQ, OT, OU, OV.

PA, PD, PK, PN, PO, PW, PY, PZ, QD, QO, QQ, QR, QT, QX, RB, RC, RE, RF, RI, RK, RM, RN, RV, RW, RY, SG, SJ, SM, TB, TI, TK, TO, TU, TV, TW, UA, UB, UC, UD, UE, UF, UG, UL, UM, UO, UT, UU, UW, UZ, VC, VE, VG, VI, VL, VN, VQ, VT, VW.

WF, WG, WI, WL, WS, WT, WW, XA, XB, XD, XE, XI, XS, XY, YZ, ZJ, ZV, ZZ.

Please send a stamped, self-addressed envelope to L. J. Fader, 125 Henry St., Halifax.

THE RADIO AMATEUR

A few years ago I did not know,
My lessons in geography;
Though I could spell and read right well,
And cipher, too, I could not tell
The least thing in topography.

But what a change! How passing strange!
This amateur radio passion
Has roused my zeal, for we or weal,
And list of names I now can reel
Off in amazing fashion.

I now can speak of Mozambique,
Haiti, Bulgaria,
China, Spain, Italy, Japan,
India, Austria, Gibraltar, Soudan,
Greenland, Siam, Bavaria.

Oh so bold this hobby told,
Genuine without a teacher.
Around the world by key and phone,
New Zealand to the Canal zone,
Panama, Wales to the Island Easter.

Now I long for such as Hong Kong,
Sarawak and Borneo,
Country to country, day by day,
Log the prefix in my own way,
And how much else, no one can know.

A. R. P. Golding,
RCSA (AA) CA/AF
Picton Airport, Ontario.



Where Experience Counts ...

The name of Westinghouse has been associated with the best in radio since radio began. The name of Westinghouse on Radio Tubes is your assurance of uniform . . . dependable long life.



Westinghouse RADIO TUBES

CANADIAN WESTINGHOUSE COMPANY LIMITED, HAMILTON, ONTARIO



BARKER & WILLIAMSON, INC.
237 Fairfield Ave. Upper Darby, Pa.

B&W

Designed for



Application

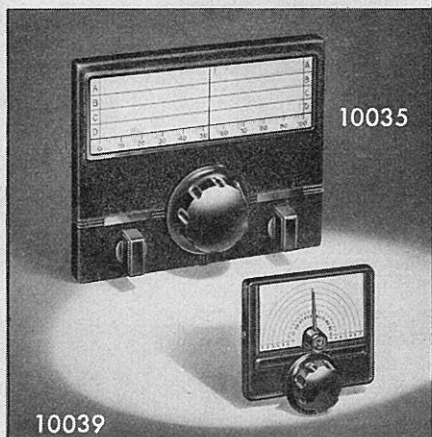

**Nos. 10035 and 10039
Multi-Scale Dials**

A pair of truly "Designed for Application" controls. Large panel style dial has 12 to 1 ratio; size, 8½" x 6½". Small No. 10039 has 8 to 1 ratio; size, 4" x 3¼". Both are of compact mechanical design, easy to mount and have totally self-contained mechanism, thus eliminating back of panel interference. Provision for mounting and marking auxiliary controls, such as switches, potentiometers, etc., provided on the No. 10035. Standard finish, either size, flat black art metal.

**JAMES MILLEN
MFG. CO., INC.**

MAIN OFFICE AND FACTORY
**MALDEN
MASSACHUSETTS**



HAM-ADS

Copy for Ham-Ads must be received before the tenth of the month preceding issue. Rate is 25 cents per line.

SELL—Hallicrafter S11X Superskyrider, magic eye, S meter, filter crystal, built-in 100 KC crystal

QSL Cards Printed—1,000 1 colour, \$6.00; 1,000 2 colour, \$8.00. W. J. Wisin and Co., 105 Princess St., Kingston, Ont.

FOR SALE—National 110 receiver with power power supply and speaker. Best offer. F. E. Burgess, 33 Holley Ave., Weston, Ont.

QSL's for discriminating hams. Distinctive! Colorful. Highest quality! \$1.50 per 100. Samples 10 cents. Ve3QS Print, 344 Pape Ave., Toronto.

FOR SALE—Globe Trotter Xmtr 80-10 meters, phone or CW, 40 watts. Used 3 months. Price \$120. Ve3ST, L. Towns, P.O. Box 572, Kenora, Ont.

SELL—Hallicrafter 511X Superskyrider, magic eye, 5 meter, filter crystal, built-in 100 KC crystal standard, 25 cycle, less speaker \$115.00. F.O.B. Niagara-on-the-Lake, Ve3AUC.

FOR SALE—One Panoramic SP 44, also one Bendix TA 12 G Transmitter with modulator and control box. Each unit \$75 or best offer. Need one 110V-60 cycle Transformer and rectifier delivering 24V-DC 20 Amps to run Bendix TA 12 G. J. Edm. Ferland, Riviere du Loup Centre, P.Q., Ve2EH.

FOR SALE—W.R.L. Globetrotter transmitter, like new, used only a few months, complete set of coils. Best offer takes. Cyril Hunt, Ve6GU, 319-2 Ave., Bowness, Alta.

FOR SALE—PE103 dynamotor, excellent for mobile, input 6 or 12 volts, output 500V at 160 Mills, \$15. Like new. Express collect from Ninga, Man.

FOR SALE—P.P. 813 R.F. Amplifier Unit with tubes and coils—best quality parts—\$75 or best offer. 150 volt 300 MA. 25 cycle plate supply—all Hammond parts—\$50 or best offer. J. H. Scott, 150 Dowling Ave., Toronto, LOMBARD 5365.

**JAMES MILLEN MFG. CO.
INC.,** Products are represented in Canada by

**ASTRAL ELECTRIC CO.
56 Wellington E., Toronto, Ont.**



WAR SURPLUS TUBES

2x240	VR15035
5BP1	3.00	211	5.00
5CP1	3.00	304TH	12.00
5GP1	3.00	801A	1.60
6AB740	802	3.00
6AJ7/6AC7..	.40	803	8.00
6AG540	805	5.00
6AK7/6AG7..	.40	*80765
6AK657	810	5.00
*6C445	811	1.90
*6J640	813	11.00
12A630	814	4.00
FG27A	5.00	815	2.00
*RK3965	826	1.50
RK6055	837	3.00
EF5035	872A	3.00
95565	88465
956	1.00	CK100640
446A (light		E114835
house)	2.00	845	3.40
205180	161965
719340	162540
900330	832	2.85
900430	900630
VR10535	830B	4.60

*These types available only while our present stock lasts. Many other types running low.

ORIGINAL REPLACEMENT TYPE TUBES

Type	For R1155 Receiver	Similar To	Your Cost
VR 99		6K8G49
VR100		6K7G49
VR101		6R7G49
VR102		6F8G49
VI 103		Eye Tube49

Quantity Limited—Order Now

STANDARD STOCK TRANSMITTING TUBES

Type	Your Cost	Type	Your Cost
809	5.10	316	1.80
312	4.35	8005	10.15

Other types also available.

TAYLOR TRANSMITTING TUBES

Type	Your Cost	Type	Your Cost
T20	3.95	T40	5.65
TZ20	3.95	TZ40	5.65
866JR	1.80	T55	9.30
866A	2.50	203Z	12.85

FREE LOG BOOK WITH EACH \$5.00 ORDER
Be Sure to Ask for Yours — Supply Limited

TRIPLETT VOLT-OHM-MIL AMMETER Model 630

DC Volts—0-3-12-60-300-1200-6000 at 20,000 Ohms per volt.	
AC Volts—0-3-12-60-300-1200-6000 at 5,000 Ohms per volt.	
DC Micro Amperes—0-60 at 250 Mv.	
DC Milliampers—0-1.2-12-120 at 250 Mv.	
DC Amperes—0-12 at 250 Mv.	
Ohms—0-1,000-10,000.	
Megohms—0-1-100.	
Output Volts—0-3-12-60-300-1200 AC at 5,000 Ohms per volt.	
Decibels — -30 to +4, 16, 30, 44, 56, 70 on 500 Ohm line.	
Your cost	47.50

SIMPSON

Model 77 Modulation Meter, Monitor, Wavemeter	32.50
QSL Cards, per 100	1.50
Samples on request.	
Beam Pointer Guide Book	1.20
Winter Call Book	2.00

LEADING WHOLESALE DISTRIBUTORS OF AMATEUR SUPPLIES IN CANADA

CANADIAN ELECTRICAL

SUPPLY CO. LTD.

MONTREAL
275 Craig St. W. PL. 3921

MI. 2481 TORONTO
543 Yonge St.



Happy Christmas

BILL PETERSEN, WØJRY



PETERSEN RADIO COMPANY, Inc.

2800 W. BROADWAY, COUNCIL BLUFFS, IOWA